

PCB LAYOUT TOP VIEW

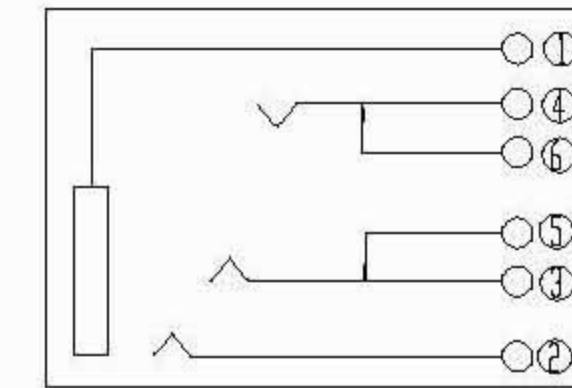

CIRCUIT DIAGRAM

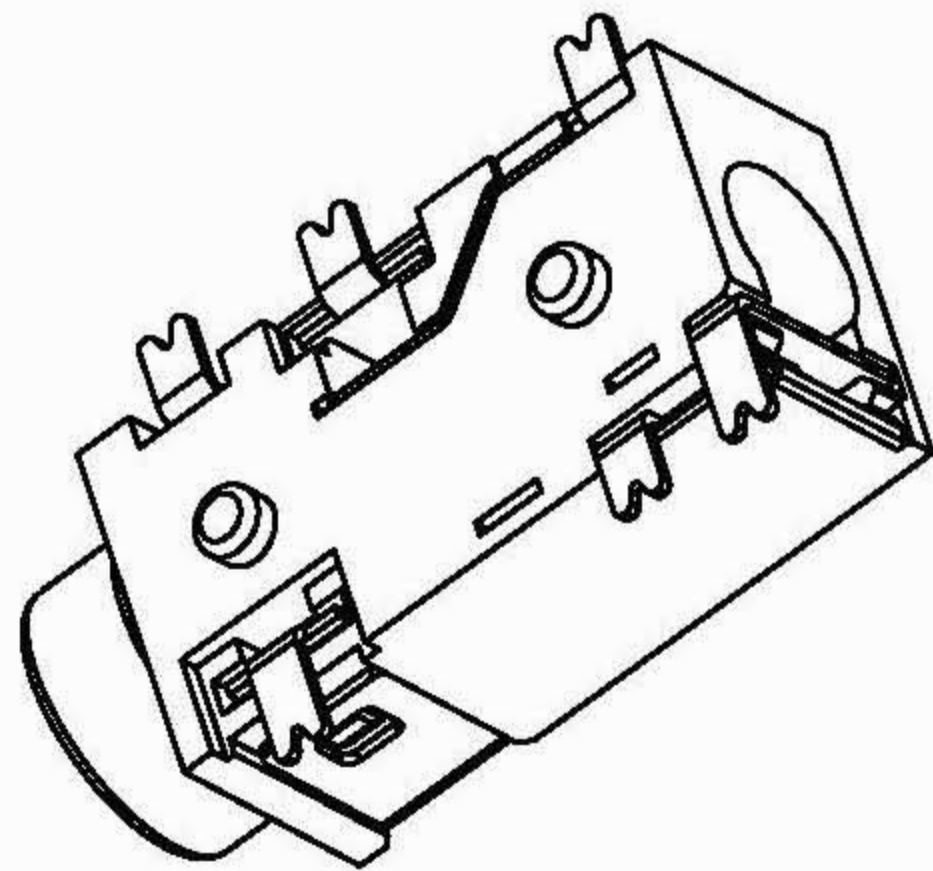

⑦	HOUSING PJ-0226	1	PA-9T (Black)	
⑥	TERMINAL PJ-0226-6#	1	PHOSPHOR BRONZE t=0.20	Au-Plated
⑤	TERMINAL PJ-0226-5#	1	PHOSPHOR BRONZE t=0.20	Au-Plated
④	TERMINAL PJ-0226-4#	1	PHOSPHOR BRONZE t=0.20	Au-Plated
③	TERMINAL PJ-0226-3#	1	PHOSPHOR BRONZE t=0.20	Au-Plated
②	TERMINAL PJ-0226-2#	1	BRASS t=0.20	Au-Plated
①	TERMINAL PJ-0226-1#	1	PHOSPHOR BRONZE t=0.20	Au-Plated
No.	PART NAME	QTY	MATERIAL (THICK, COLOR)	REMARK

ANGULAR	±5°
16 < L ≤ 63	±0.3
4 < L ≤ 16	±0.2
L ≤ 4	±0.15
UNSPECIFIED TOLERANCE	

DSND	CHENCHAO	DATE	2008-05-14	SCALE: 4 : 1
CHKD		DATE		VIEW:
APVD		DATE		UNIT: mm

NAME:	EARPHONE JACK
CAT. NO.	ST-0326AS-060-100 ROHS
DWn. NO.	Q/XL-QW-001A-0427